

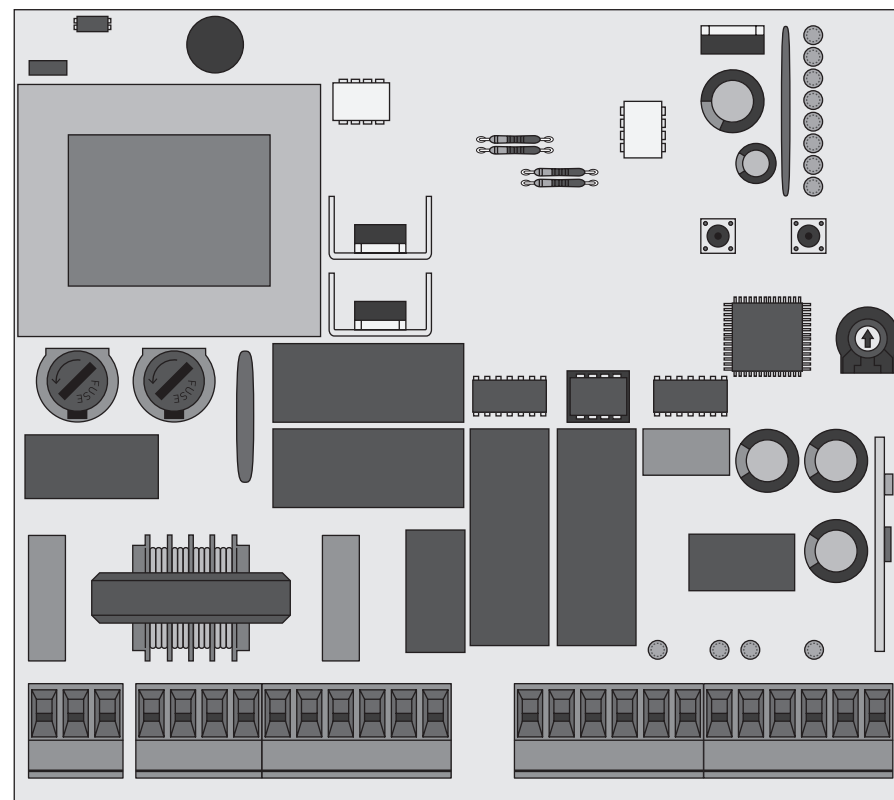

MC2

USER / INSTALLER MANUAL



00. CONTENT

INDEX

01. SAFETY INSTRUCTIONS	
STANDARDS TO FOLLOW	1B
02. THE CONTROL BOARD	
TECHNICAL SPECIFICATIONS	2A
PROGRAMMING PRE-RECOMENDATIONS	3A
03. CONFIGURATION	
MAIN MENU	4A
EXTENDED MENU 1	6B
EXTENDED MENU 2	8A
EXTENDED MENU 3	9B
RESET OF CONTROL BOARD	10A
04. COMPONENT TEST	
PHOTOCELLS TESTING AND REMOTE CONTROLS	10A
CAPACITATOR SCHEME	10B
05. TROUBLESHOOTING	
INSTRUCTIONS FOR FINAL CONSUMERS	11
INSTRUCTIONS FOR SPECIALIZED INSTALLERS	11
06. CONNECTION SCHEME	
CONTROL BOARD CONNECTION COMPONENT	12

01. SAFETY INSTRUCTIONS

STANDARDS TO FOLLOW

ATTENTION:

- To ensure the safety of people, it is important that you read all the following instructions.
- Incorrect installation or incorrect use of the product can cause physical injury and material damage.
- This product was designed and produced strictly for the use indicated in this manual. Any other use, not expressly indicated here, could compromise the good condition/operation of the product and/or be a source of danger, and will void the warranty.
- **ELECTROCELOS S.A.** is not responsible for the improper use of the product, or other use than that for which it was designed.
- **ELECTROCELOS S.A.** is not responsible if safety standards were not taken into account when installing the equipment, or for any deformation that may occur to it.
- **ELECTROCELOS S.A.** is not responsible for the safety and proper operation when using components not sold by them.
- Do not make any modifications to the operator components and / or their accessories.
- Before installation unplug the automatism from the source of power.
- The installer must inform the client how to handle the product in case of emergency and provide this manual to user.
- Keep remote controls away from children, to prevent the automated system from being activated involuntarily.
- The customer shall not, under any circumstances, attempt to repair or tune the automatism. Must call qualifid technician only.
- Connect the automatism to a 230V plug with ground wire.
- Control board for indoor use.

02. THE CONTROL BOARD

TECHNICAL SPECIFICATIONS

The MC2 is a central electronic single phase with incorporated radio, for automation of swing gates.

• Power supply	230V AC 50-60Hz
• Lightbulb's output	230V AC 500W máx.
• Motor's output	230V AC 50/60 Hz 500W máx.
• Auxiliary accessories output	24V AC 15W máx.
• Safety and remote controls in BT	24V CC
• Working temperature	-10°C to +55°C
• Protection	IP56
• Incorporated Radio Receiver	433,92 Mhz
• OP Transmitters	12-18 bits or Rolling Code
• Maximum memory capacity	150 (CODE or CODE PED)

• DIMENSIONS THE BOX AND CONTROL BOARD

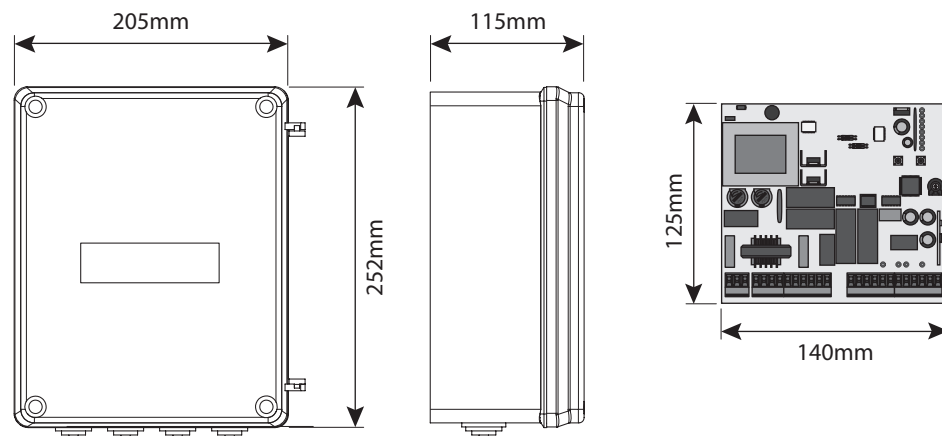

02. THE CONTROL BOARD

TECHNICAL SPECIFICATIONS

• CONNECTOR'S DESCRIPTION

CN1	<ul style="list-style-type: none"> 01 • Earth connection 02 • Earth connection 03 • Earth connection
CN2	<ul style="list-style-type: none"> 01 • AC 230V Line Input (PHASE) 02 • AC 230V Line Input (NEUTRAL) 03 • Lightbulb / Courtesy light's output (not blink) AC230V (NEUTRAL) 04 • Lightbulb / Courtesy light's output (not blink) AC230V (PHASE) 05 • Motor's Output 1 opening 06 • Motor's Output 1 common 07 • Motor's Output 1 closing 08 • Motor's Output 2 opening 09 • Motor's Output 2 common 10 • Motor's Output 2 closing
CN3	<ul style="list-style-type: none"> 01 • Output for power photocells 24V AC 02 • Output for power photocells (earth) 03 • Output for electric lock 12V DC 15W (+12V) 04 • Output for electric lock 12V DC 15W (earth) 05 • Input PUL button the order opening / closing (NA) 06 • Input earth common 07 • Input PUL PED button the order pedestrian (NA) 08 • Input DS1 safety device 1 (NC) 09 • Input common GND 10 • Input DS2 safety device 2 (NC) 11 • Antena mass input 12 • Antena hot pole input

02. THE CONTROL BOARD

PROGRAMMING PRE-RECOMENDATIONS

Before proceeding to the control board configuration, note the following points listed in the table below:

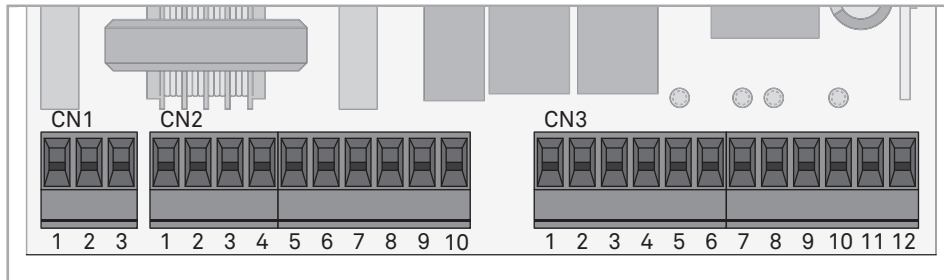

CN2

Flash lamp:

03 and 04 • This output allows connection of a flash lamp (see page 4B).

Capacitor:

05 and 07 • You must connect the capacitor between the outputs 05 and 07.
08 and 10 • You must connect the capacitor between the outputs 08 and 10.

CN3

Electric lock:

03 and 04 • This output allows connection of an electric lock (see pág.9A)

Push button / selector:

05 • Allows connection the push-button / selector to full opening (NA).
06 • Allows connection the push-button / selector to full opening (NA).

Safety circuits:

08 • This circuit allows the connection of all types of safety devices such as photocells, safety edge, etc.
 This device operates only in the gate closing and, when activated change the direction of the automation.

10 • This circuit allows the connection of all types of safety devices such as photocells, safety edge, etc.
 This device operates in the opening and closing. In closing, change the direction of the automation. In the opening for the movement and when was released continues with the opening.

02. THE CONTROL BOARD

PROGRAMMING PRE-RECOMENDATIONS

• PROGRAMMING THE CONTROL BOARD - BUTTONS SEL/SET

SEL button: It makes the selection of the function to change. The selection is identified by the flashing of the LED corresponding to the selected function at that time.

Pressing the SEL button repeatedly will cycle through the various functions to be programmed. The selection remains active for 10 seconds, after these time the control board returns to original status (no active selection).

SET button: Makes programming the selected function through the SEL button.



The SET button may be substituted by a remote control from the latter is programmed.

• POWER AND SPEED OF MOTORS

The control board has a trimmer VR1 for adjusting the force and speed of the motors controlled by the microprocessor. The adjustment can be effected between 50% and 100% the power.

At each start-up movement, the control board applies the maximum power during 2 seconds, even when it is made regulating force to a value than not the maximum.



When you adjust the trimmer VR1 has to remake course programming, as they could varied the times of maneuvering and deceleration.

• OPERATION OF FLASH LAMP

The operation of the output is conditioned by the movement of the motor and automatic closing. When the automatic closing is activated, the 230V output is activated even during pause time.

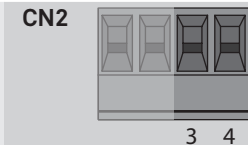

• OPERATION WITH TIMER

Instead of a push button opening / closing (PUL), the control board can be operated with a TIMER. With a TIMER connected to the control board it is possible to program an exact time for that the motor perform both the opening and closing, in the automatic mode.

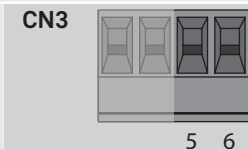

03. CONFIGURATION

MAIN MENU

This is the main menu of the control board MC2, which has access to the most important functions of its operation. The control board is supplied with the active main menu.

MAIN MENU		
LED	LED OFF	LED acceso
• AUT/P-P	LED OFF	Step by step
• CODE	Automatic	Inserted code
• CODE PED.	No code	Inserted code
• INB. CMD. AP	No code	Activated
• T. MOT.	Deactivated	Programmed time
• T. MOT. PED	Motor time 30 s.	Programmed time
• T. PAUSA.	Motor time pedestrian 10 s.	With automatic closing
• T. RIT. ANTE	Without automatic closing	Programmed time

• AUT/P-P | AUTOMATIC OPERATION / STEP BY STEP

Mode automatic operates (LED AUT / P-P off):

- The first impulse the remote control / puss button activates the opening until the end of the motor time.
- The second impulse the remote control / puss button activates the closing until the end of the motor time.

If give an impulse before the end of the motor time, the control board will perform a inversion of movement in opening and closing.

Mode of operation step by step (LED AUT / P-P on):

- The first impulse the remote control / puss button activates the opening until the end of the motor time.
- The second impulse the remote control / puss button activates the closing until the end of the motor time.

If give one order before the end of the motor time, the control board will stop the movement in opening and closing. A new order will return the operation, performed in the other direction to what it was before the stop.

The control unit is supplied by the manufacturer with the activated Automatic mode (LED AUT / P-P off).

Note: If the T. PAUSE is active (on) and stop the gate during the opening, this will keep stopped until the end of the pause time, and then make the closing. If you stop during

03. CONFIGURATION

MAIN MENU

closing, it will stop and will restart only when receive new order.

Select operating mode:

01. Press the **SEL** button once, and the **LED AUT / P-P** will start flashing.

02. Press the **SET** button for 1 second.

03. The **LED AUT/PP** lit signals that are selecting the mode of operation step by step and the LED off signals that is selected the automatic mode.

• CODE | PROGRAMMING OF REMOTE CONTROLS

The control board accepts only Dip-Switch remote controls or Rolling Code MOTORLINE, and has a maximum capacity of 150 remote controls. When trying to program the 151 remote controls, all the programming LEDs will flash simultaneously to indicate that the memory is full.

To program new remote controls:

01. Press the **SEL** button as many times as necessary until the **LED CODE** flashes.

02. Press once the button remote control you want to program for 1 second.

03. The **CODE LED** lights up permanently, indicating successful programming.

To delete all configured remote controls:

01. Press the **SEL** button once, and the **CODE LED** will begin to flash.

02. Press the **SET** button once! The **CODE LED** turns off and all remote controls have been deleted.

If the **CODE LED** starts fast flashing, means that the control board did not accept the remote controls programming, because of the following reasons:

- The remote control is already programmed;
- The control board accepts only remote controls with rolling code.

• CODE PED | PEDESTRIAN OPERATION

The control board allows starting only one motor for the possible passage of peoples. With this function, pressing the remote control, only the leave of motor 1 will open.

Programming the remote controls to pedestrian mode (LED CODE PED ON) / the remote controls (LED CODE OFF):

01. Press the **SEL** button once until the **LED CODE PED** starts flashing.

02. Press the remote control button that you want to program during 1 second.

If you want delete remote controls, press the **SET** button for 1 second.

03. **LED CODE PED ON** indicates that the remote controls is programmed and deleted LED indicates that the remote controls have been deleted.

03. CONFIGURATION

MAIN MENU

• INB. CMD. AP | TRANSMITTER INHIBITION DURING THE OPENING AND PAUSE TIME

With the function activated, the control board rejects all the remote controls signals during the opening maneuvers and automatic pause time. It's important that this function is activated during a magnetic loop installation, because the control board will ignore the crossings performed during the opening and the pause time.

The control board is supplied by the manufacturer with this function deactivated.

Activate (LED ON) / deactivate (LED OFF) function:

01. Press the **SEL** button the times necessary until the **LED INB CMD AP** starts to flash.
02. Press **SET** button for 1 second to enable / disable the function.
03. The **LED INB CMD AP ON** indicates that the function is active and the **LED OFF** indicates that the function is deactivated.

• T. MOT AND DECELERATION | MOTOR TIME PROGRAMMING AND DECELERATION

With this function can actuate the slowdown, decreasing the gate's movement speed.

NOTA • To perform this programming is necessary that the motors have limit switch or mechanical stop.

Instead of using the **SET** button of the control board, you can use a remote control that is already programmed.

The control board is supplied by the manufacturer with a working time of motors established within 30 seconds, without deceleration.

Program working time of the motor with deceleration (Gate closed):

01. Press the **SEL** button the times necessary until the **LED T.MOT.** start to flash.
02. Press the **SET** button for 1 second, so that the Motor 1 start opening. **If the motor does not accept the opening, invert the cable connections 5 and 7, the CN2 connector (see page 2B).**
03. Press the **SET** button for 1 second, when the gate is the desired point to start deceleration.
04. Press again **SET** button when you want to establish the opening limit switch. At this time, **LED T. MOT.** will quickly flashing and automatically the motor 2 starts opening maneuver.
05. Press the **SET** button for 1 second, when the gate is in the desired point to start deceleration.
06. Press again **SET** button when you want to establish the opening limit switch.
07. The **T. MOT.** will quickly flashing indicating that programming for closing can be performed and automatically the motor 2 starts the closing maneuver. Repeat the process to program the closing.

03. CONFIGURATION

MAIN MENU

Program working time of the motor without deceleration (Gate closed):

01. Press the **SEL** button the times necessary until the **LED T.MOT.** start to flash.
02. Press the **SET** button for 1 second, so that the Motor 1 start opening. If the motor does not accept the opening, invert the cable connections 5 and 7, the CN2 connector (see page 2B).
03. Press twice the **SET** button when the gate is in the desired point to finish the opening course. At this time, **LED T. MOT.** will quickly flashing and automatically the motor 2 starts opening maneuver.
04. Press **SET** button two times when desires to establish the opening limit switch.
05. The **T. MOT.** will quickly flashing indicating that programming for closing can be performed and automatically the motor 2 starts the closing maneuver. Repeat the process to program the closing.

• T. MOT. PED | PROGRAMMING PEDESTRIAN WORKING TIME

To activate the pedestrian function, the control board allows to be just activated the operation of motor 1.

NOTE • To perform this programming is necessary that the motors have limit switches or stoppers.

Instead of using the **SET** button on the control board, you can use a remote control that is already programmed.

The control board is supplied by the manufacturer with a pedestrian working time established in 10 seconds without deceleration.

Programming pedestrian working time with deceleration (gates closed):

01. Press **SEL** button as often as necessary until the **LED T. MOT. PED.** starts flashing.
02. Press the **SET** button for 1 second, so that the Motor 1 start opening. **If the motor does not accept the opening, invert the cable connections 5 and 7, the CN2 connector (see page 2B).**
03. Press the **SET** button for 1 second, when the gate is the desired point to start deceleration.
04. Press again **SET** button when you want to establish the opening limit switch. At this time, **LED T. MOT.** will quickly flashing and automatically the motor 1 starts closing maneuver.
05. Press the **SET** button when the gate is in the desired point to start deceleration.
06. Press again **SET** button when you want to establish the closing limit switch.
07. The **LED T. MOT.** will light, signaling that the working time is programmed.

03. CONFIGURATION

MAIN MENU

Programming pedestrian working time without deceleration (gates closed):

01. Press **SEL** button as often as necessary until the **LED T. MOT. PED.** starts flashing.
02. Press the **SET** button for 1 second, so that the Motor 1 start opening. **If the motor does not accept the opening, invert the cable connections 5 and 7, the CN2 connector (see page 2B).**
03. Press twice the **SET** button, when you want to establish the opening limit switch. At this time, **LED T. MOT.** will quickly flashing and automatically the motor 1 starts closing maneuver.
04. Press twice the **SET** button when you want to establish the closing limit switch.
05. The **LED T. MOT.** will light, signaling that the working time is programmed.

• T. PAUSA | PROGRAMMING AUTOMATIC CLOSING

The control board permits an automatic closing after a set waiting time, maximum until 4 minutes.

The control board is supplied by the manufacturer with this function disabled.

NOTE • Instead of using the **SET** button on the control board, you can use a remote control that is already programmed.

Activate (LED ON)/deactivate (LED OFF) function:

1. Press **SEL** button as often as necessary until the **LED T. PAUSA** starts flashing.
2. Press the **SET** button for 1 second. From that moment, the waiting time before pressing **SET** will be equal to the time that the gate stays open.
3. Press the **SET** button for 1 second, when you reach the time that you want for the automatic closing.
4. The **LED T.PAUSA ON** indicates that the function is active and the LED off indicates that the function is disabled.

• T. RIT. ANTE | PROGRAMMING DOOR DELAY

This function can delay up to 15 seconds the start of the closing motor 1 in relation to the motor 2.

At the opening, the difference between the motor starting motor 2 to 1 is always 2 seconds.

The unit is supplied by the manufacturer with this function disabled.

Programming:

01. Press the **SEL** button as often as necessary until the **LED T. RIT. ANTE** starts flashing.

03. CONFIGURATION

MAIN MENU

02. Press the **SET** button for 1 second. From that moment, the waiting time before pressing **SET** will be equal to the time that the gate stays open.

03. Press the **SET** button for 1 second, when you reach the time that you want. Therefore, on closing, the delay time will be stipulated by the option while the opening is fixed in 2 seconds.

04. The **LED T. RIT. ANTE** will light permanently, indicating the memorization time delay between motor 1 and motor 2.

Delete programming:

01. Press the **SEL** button until the **LED T. RIT. ANTE** will flashing.
02. Press the **SET** button twice in less than 2 seconds.
03. The **LED T. RIT. ANTE** will off, signaling the success of the operation.

EXTENDED MENU 1

The control board is supplied by the manufacturer with an extended menu 1, which allows access to more functions of the control board.

To access the options of extended menu 1 follow these instructions:

01. Press continuously the **SET** button for 5 seconds and the **LED T.PAUSA** and **LED T. RIT. ANTE** will flash alternately.
02. You have 30 seconds to select functions from the extended menu 1 (using the **SEL** and **SET** button), and that after this time the control board returns to main menu.

EXTENDED MENU 1		
LED	LED OFF	LED ON
• AUT/PP.	PGM distance OFF	PGM distance ON
• CODE	Photocells test ON	Photocells test OFF
• CODE PED.	Pressure maintenance OFF	Pressure maintenance ON
• INB. CMD. AP	Opening push OFF	Opening push ON
• T. MOT.	Closing push OFF	Closing push ON
• T. MOT. PED	Safety device 2	Blockade entrance
• T. PAUSA.	Alternative intermittence ON/OFF	
• T. RIT. ANTE	Alternative intermittence ON/OFF	

03. CONFIGURATION

EXTENDED MENU 1

• AUT/P-P | PROGRAMMING OF THE REMOTE CONTROL ON DISTANCE

The function of programming the remote controls on distance, it allows them to be added remote controls to the new control board without having to use the **SEL** button. The control board is supplied by the manufacturer with programming remote controls on distance deactivated.

Activate (LED ON) / deactivate (LED OFF) function:

01. Activate the extended menu 1.
02. Press **SEL** button once and the **LED AUT/P-P** will begin to flash.
03. Press for 1 second the **SET** button.
04. **LED AUT/P-P ON** indicates that the function is active and the **LED off** indicates that the function is disabled.

Programming of remote controls on distance:

01. Press for 10 seconds the button of the remote control a previously memorized.
02. **LED CODE** will flash.
03. Press for 1 second one button of the remote control that you want to program.
04. The flash lamp will flash confirming the success of the operation.

• CODE | TEST OF PHOTOCELLS

The control board is supplied by the manufacturer with the deactivated photocells test.

Activate (LED ON)/deactivate (LED OFF) function:

01. Activate the extended menu 1
02. Press **SEL** button once and the **LED AUT/P-P** will begin to flash.
03. Press **SET** button for 1 second
04. The **LED CODE ON** indicates that the function is disabled and the **LED off** indicates that the function is activated.

NOTE • If you do not have the photocells installed, this test will not work.

• CODE PED | MOTORS PRESSURE

The pressure function of the motors, makes that with control board send the order of 2 seconds of closing, once every two hours.

The control board is supplied by the manufacturer with functionality to keep pressure OFF the hydraulic motors.

Activate (LED ON)/deactivate (LED OFF) function:

01. Activate the extended menu 1.
02. Press **SEL** button as often as necessary until the **LED CODE PED** will flashing

03. CONFIGURATION

EXTENDED MENU 1

03. Press **SET** button for 1 second

04. The **LED CODE PED** on indicates that the function is activated and the **LED off** indicates that the function is disabled.

• INB. CMD. AP. | OPENING PUSH OF

The function opening push, facilitates the release of the lock when the opening is actuated, ensuring proper operation.

The control board is supplied by the manufacturer with the opening push disabled.

Activate (LED ON)/deactivate (LED OFF) function:

01. Activate the extended menu 1.
02. Press **SEL** button as often as necessary until the **LED INB. CMD. AP.** will flashing
03. Press **SET** button for 1 second
04. The **LED INB. CMD. AP** on indicates that the function is activated and the **LED off** indicates that the function is disabled.

• T. MOT. | CLOSING PUSH

With the closing push function, the control board case is programmed with deceleration, will add 1 second acting at full motor power, so that the gate can overcome the lock.

The control board is supplied by the manufacturer with the closing push disabled.

Activate (LED ON)/deactivate (LED OFF) function:

01. Activate the extended menu 1.
02. Press **SEL** button as often as necessary until the **LED T. MOT.** will flashing
03. Press **SET** button for 1 second
04. The **LED T.MOT.** on indicates that the function is activated and the **LED off** indicates that the function is disabled.

• T. MOT. PED | SAFETY DEVICE 2 / BLOCKING

With the blocking function activated whenever the photocells (DS2) detected an obstacle, the gate movement will stop and only again be triggered when you press the remote control button. Before the gate resume movements, the flash lamp will flash during 5 seconds.

The control board is supplied by the manufacturer with blocking disabled.

03. CONFIGURATION

EXTENDED MENU 1

Activate (LED ON) / deactivate (LED OFF) function:

01. Activate the extended menu 1.
02. Press **SEL** button as often as necessary until the **LED T. MOT.** will flashing.
03. Press **SET** button for 1 second.
04. The **LED T.MOT.** on indicates that the function is activated and the **LED** off indicates that the function is disabled.

EXTENDED MENU 2

The control board is supplied by the manufacturer with an extended menu 2, which provides access to more functions to the control board.

To access the options menu extended 2 proceed as follows:

01. Enter the extended menu 1 (see page 06.B).
02. Press continuously the **SET** button for 5 seconds and the **LED T.PAUSA** and **LED T. RIT. ANTE** will flash simultaneously.
03. You have 30 seconds to select functions from the extended menu 2 (using the **SEL** and **SET** button), and after this time the control board returns to the main menu.

EXTENDED MENU 2		
LED	LED OFF	LED ON
• AUT/P.P.	Follow Me OFF	Follow Me ON
• CODE	Pre Flash Lamp OFF	Pre Flash Lamp ON
• CODE PED.	Flash lamp on pause OFF	Flash lamp on pause ON
• INB. CMD. AP	Soft start OFF	Soft start ON
• T. MOT.	Electronic lock PED OFF	Electronic lock PED ON
• T. MOT. PED	PUL=PUL PED=PED	PUL=AB PED=FECH
• T. PAUSA.	Intermittent ON/OFF simultaneously	
• T. RIT. ANTE	Intermittent ON/OFF simultaneously	

03. CONFIGURATION

EXTENDED MENU 2

• **AUT/P-P** | FOLLOW ME

With the programmed pause time, it is possible to trigger "Follow Me" option. With this option enabled, whenever the photocells detected the passage of a user/object, the control board triggers the closing maneuver after 5 seconds.

Activate (LED ON) / deactivate (LED OFF) function:

01. Enter the extended menu 2.
 02. Press once the **SET** button and the **LED AUT/P-P** will flash.
 03. Press once **SET** button to enable / disable the function.
- The **LED AUT/PP ON** signals that the function is activated and the **LED OFF** signals that the function is disabled.

• **CODE** | PRE FLASH LAMP/LAMP.CORT

With the functioning in pre flash lamp, the output 03 and 04 (CN2) will always be activated 3 seconds before the automation start a movement. When disabled, the function returns flash lamp.

The control board is supplied by the manufacturer with the pre flash lamp disabled.

Activate (LED ON)/deactivate (LED OFF) function:

01. Enter the extended menu 2.
 02. Press **SEL** button as often as necessary until the **LED CODE** will flashing
 03. Press once **SET** button to enable / disable the function.
- The **LED CODE ON** signals that the function is activated and the **LED OFF** signals that the function is disabled.

• **CODE PED** | OPERATION OF OUTPUT 230V FOR FLASH LAMP DURING THE PAUSE TIME

With this option enabled, whenever the motor is in pause time at output 230V for flash lamp will stay on.

The control board is supplied by the manufacturer with the flash lamp paused, disabled.

Activate (LED ON) / deactivate (LED OFF) function:

01. Enter the extended menu 2.
 02. Press **SEL** button as often as necessary until the **LED CODE PED** will flashing.
 03. Press once **SET** button to enable / disable the function.
- The **LED CODE PED ON** indicates that the function is activated and the **LED OFF** signals that the function is disabled.

03. CONFIGURATION

EXTENDED MENU 2

• INB. CMD. AP. | SOFT START

With function "Soft Start" enabled, the beginning of each movement, the control board will control start the motor, increasing power gradually in the first 2 seconds of operation.

The control board is supplied by the manufacturer with the "Soft Start" disabled.

Activate (LED ON) / deactivate (LED OFF) function:

01. Enter the extended menu 2.
02. Press **SEL** button as often as necessary until the **LED INB. CMD. AP.** will flashing.
03. Press once **SET** button to enable / disable the function.

The **LED INB. CMD. AP. ON** indicates that the function is activated and the **LED OFF** signals that the function is disabled.

• T. MOT. | ELECTRONIC LOCK IN PEDESTRIAN FUNCTION

The electronic lock on the pedestrian function is used when there is, for example, a swing doors assembled with electric lock to close the leaf 2. This makes it possible to obtain the opening of the gate to trigger a push-button connected in PUL, PED or to trigger the remote control.

The remote control is supplied by the manufacturer with the electronic lock on the pedestrian function disabled.

Activate (LED ON)/deactivate (LED OFF) function:

01. Enter the extended menu 2.
02. Press **SEL** button as often as necessary until the **LED T. MOT.** will flash.
03. Press once **SET** button to enable / disable the function.

The **LED T. MOT. ON** indicates that the function is activated and the **LED OFF** signals that the function is disabled.

• T. MOT. PED | OPERATIONS THE INPUTS PUL AND PED

The control board permits that the PUL input work with a push button (NA) exclusively for opening and PED input work with a push button (NA) only for closing.

The control board is supplied by the manufacturer with the operation of the PUL input for connection to a primary push-button (NA) cyclic and PED input for connecting a pedestrian pushbutton (NA) cyclic.

03. CONFIGURATION

EXTENDED MENU 2

PUL= opening, PED= closing (LED ON) / PUL=PUL and PED=PED (LED OFF):

01. Enter the extended menu 2.
02. Press **SEL** button as often as necessary until the **LED T. MOT. PED** will flash.
03. Press once **SET** button to change the function.

The **LED T. MOT. PED ON** signals that the **PUL** is programmed for opening and **PED** to closing. The LED off indicates that the function **PUL** if found programmed to function with a main push button (NA) cyclic and **PED** input for connecting a pedestrian pushbutton (NA) cyclic.

EXTENDED MENU 3

With the extended menu 3 can program the power / motor speed at which will be performed the deceleration.

To access the options menu Extended 3 proceed as follows:

01. Enter the extended menu 1 (see page 06.B).
02. Enter the extended menu 2 (see page 08.A).
03. Continuously press the **SET** button for 5 seconds and the **LED T.PAUSA** and **LED T. RIT. ANTE** will flash alternately a few moments, past to flash simultaneously immediately afterwards.
04. You have 30 seconds to select from the extended menu functions 3 (using the **SEL** and **SET** button), and after of this time the control board returns to the main menu.

EXTENDED MENU 3	
LEVEL OF THE POWER	LEDS ON
1	AUT/P-P.
2	AUT/P-P. • CODE
3	AUT/P-P. • CODE • CODE PED
4	AUT/P-P. • CODE • CODE PED • INB. CMD. AP
5	AUT/P-P. • CODE • CODE PED • INB. CMD. AP • T. MOT.
6	AUT/P-P. • CODE • CODE PED • INB. CMD. AP • T. MOT. • T. MOT. PED

03. CONFIGURATION

EXTENDED MENU 3

Motor power programming during the deceleration:

It is possible to choose up to 6 different levels, relatively the force that the motor performs in deceleration. The levels are represented by combinations of the LED indicated in the table above.

Scroll through the LEDs with the **SEL** button to set the desired power, knowing that the **LED AUT / P-P. ON** corresponds to minimum power, while the **LEDs AUT / P-P., CODE, CODE PED, INB. CMD. AP, T. MOT., T. MOT. PED ON** corresponds to maximum power.

The control board is supplied by the manufacturer with the power regulated at level 3 (**AUT / P-P., CODE, CODE PED ON**).

RESET TO CONTROL BOARD

If you need to restore central with factory setting, press the **SEL** and **SET** buttons simultaneously. All LEDs will light up temporarily, and when deleted is confirmed the success of the operation.

PHOTOCELLS AND CONTROLS TEST

• PHOTOCELLS TEST

The control board is prepared to a safety device connection in accordance with the section 5.1.1.6 of standard EN 12453. In every maneuver is performed a test for the Security Device and the Lock. In case of a function/connection failure the motor doesn't start and every LED's remain in a intermittent mode, indicating the error. When the photocells operation is corrected, the control board returns to its normal functioning. This action by the control board allows to recognize failures in accordance with is mentioned in category 2 of EN 954-1.

• REMOTE CONTROLS TESTE

In the position corresponding to each transmitter input in low voltage, the control board has a LED to identify the condition of it. The LED on indicates that the input is closed, while the LED off indicates that the input is open.

04. COMPONENT TEST

CAPACITORS CONNECTION SCHEME

To detect which components have problems on an automated system, sometimes it is necessary to conduct tests using a direct connection to a 230V AC power supply. For this it is necessary to merge a 8 μ F capacitor to make the automation to work. In the scheme below is shown how this link should be made and how to merge the different wires of the components.

NOTES:

- To perform these tests you don't need to remove the automation from where it is installed, because this way you can know if connected directly to power supply it will work correctly.
- The order of wiring capacitor to motor wires is not important, as long you connect one wire to brown wire of motor and the other one to black wire of motor;
- Common wire should always be connected to power supply.
- To reverse motor direction, just replace black wire with brown wire of the operator on the power supply.

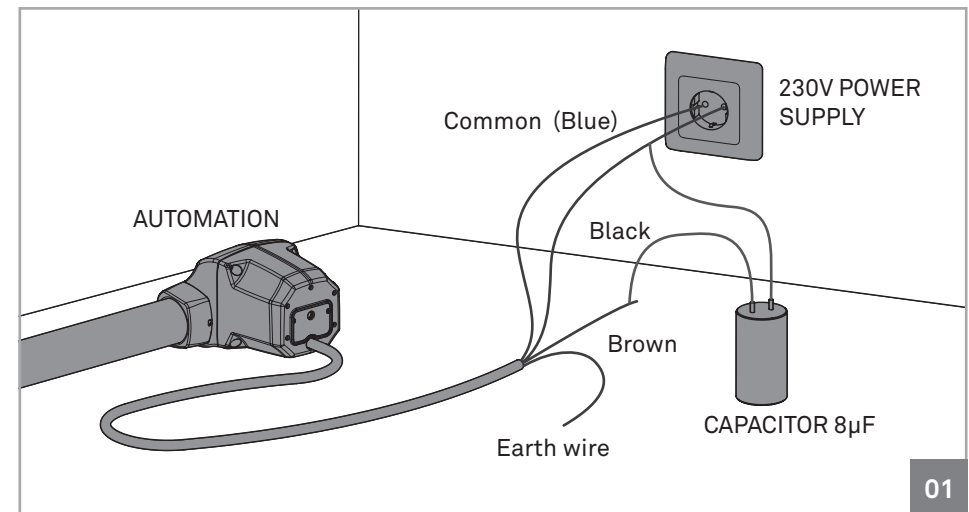

This test only applies to 230V motors. To test a 24V motor, just connect the motor cables to a 24V battery.

05. TROUBLESHOOTING

FINAL CONSUMERS INSTRUCTIONS

INSTRUCTIONS FOR SPECIALIZED INSTALLERS

Anomaly	Procedure	Behavior	Procedure II	Discovering the origin of the problem			
• Motor doesn't work	• Make sure you have 230V power supply connected to automation and if it is working properly.	• Still not working	• Consult a qualified MOTORLINE technician.	1 • Open control board and check if it has 230V power supply; 2 • Check the control board input fuses;	3 • Disconnect the motor from control board and test them by connecting directly to power supply in order to find out if they have problems (see page 10.B).	4 • If the motor works, the problem is on the control board. Pull it out and send it to our MOTORLINE technical services for diagnosis;	5 • If the motor doesn't work, remove them from installation site and send to our MOTORLINE technical services for diagnosis.
• Motor doesn't move but makes noise	• Unlock motor and move the gate by hand to check for mechanical problems on the movement.	• Encountered problems?	• Consult an experienced gate expert.	1 • Check all motion axis and associated motion systems related with the motor and the gate to find out what is the problem.			
		• The gate moves easily?	• Consult a qualified MOTORLINE technician.	1 • Check capacitors, testing operator with new capacitors;	2 • If capacitors are not the problem, disconnect motors from control board and test them by connecting directly to power supply in order to find out if they have problems (see page 10.B);	3 • If the motors work, the problem is from control board. Pull it out and send it to our technical services for diagnosis;	4 • If the motors doesn't work, remove them from installation site and send to our MOTORLINE technical services for diagnosis.
• Motor opens but doesn't close	• Unlock motor and move the gate by hand to closed position. Lock motor again and turn off power supply for 5 seconds. Reconnect it and send order to open gate using transmitter.	• Gate opened but didn't close again.	1 • Check if there is any obstacle in front of the photocells; 2 • Check if any of the control devices (key selector, push button, video intercom, etc.) of the gate are jammed and sending permanent signal to control unit; 3 • Consult a qualified MOTORLINE technician	All MOTORLINE control boards have LEDs that easily allow to conclude which devices are with anomalies. All safety devices LEDs (DS) in normal situations remain On. All "START" circuits LEDs in normal situations remain Off. If LEDs devices are not all On, there is some security systems malfunction (photocells, safety edges), etc. If "START" circuits LEDs are turn On, there is a control device sending permanent signal.	A) SECURITY SYSTEMS: 1 • Close with a shunt all safety systems on the control board (check manual of the control board in question). If the automated system starts working normally check for the problematic device. 2 • Remove one shunt at a time until you find the malfunction device. 3 • Replace it for a functional device and check if the motor works correctly with all the other devices. If you find another one defective, follow the same steps until you find all the problems.		B) SISTEMAS DE START: 1 • Disconnect all wires from START terminal input. 2 • If the LED turned Off, try reconnecting one device at a time until you find the defective device. NOTE: In case procedures described in sections A) and B) don't result, remove control board and send to our technical services for diagnosis.
• Gate doesn't make complete route	• Unlock motor and move gate by hand to check for mechanical problems on the gate.	• Encountered problems?	• Consult an experienced gate expert.	1 • Check all motion axis and associated motion systems related with the gate to find out what is the problem.			
		• The gate moves easily?	• Consult a qualified MOTORLINE technician.	1 • Check capacitors, testing with new capacitors; 2 • If capacitors are not the problem, disconnect motor from control board and test it by connecting directly to power supply in order to find out if it is broken; 3 • If the motor doesn't work, remove it from installation site	and send to our MOTORLINE technical services for diagnosis. 4 • If motor work well and move gate at full force during the entire course, the problem is from controller. Set force using trimmer on the board. Make a new working time programming, giving sufficient time for opening and closing with appropriate force (page 08.B).	5 • If this doesn't work, remove control unit and send it to MOTORLINE technical services.	NOTE: Setting force of the controller should be sufficient to make the gate open and close without stopping, but should stop and invert with a little effort from a person. In case of safety systems failure, the gate shall never cause physical damaged to obstacles (vehicles, people, etc.).

06. CONNECTION SCHEME

CONTROL BOARD CONNECTION COMPONENT

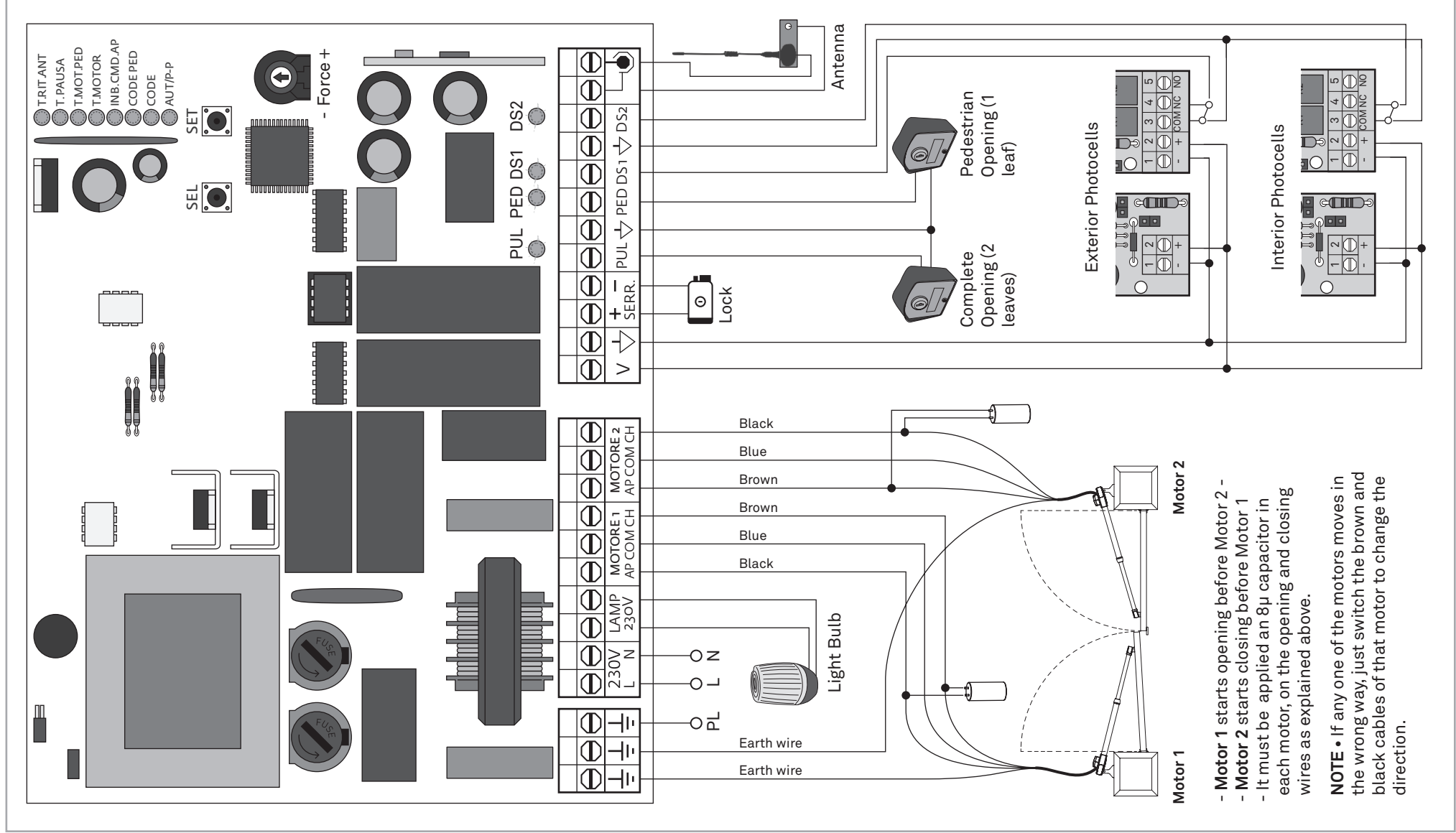

- Motor 1 starts opening before Motor 2 -
- Motor 2 starts closing before Motor 1
- It must be applied an 8µ capacitor in each motor, on the opening and closing wires as explained above.

NOTE • If any one of the motors moves in the wrong way, just switch the brown and black cables of that motor to change the direction.